

AXEL XL

Gijs Papavoine 2014



ROMP

Houten constructie van beuken regels, mdf panelen, etc.
No-sag veren
Polyether bedekt met 90gr dacron.

ONDERSTEL

Slede:

- RVS
- Mat zwart

Aluminium poten:

- hoogglans gepolijst
- hoogglans zwart verchromd

De Axel XL is ook met 2 cm lagere poten te verkrijgen. Bij de afgebeelde modellen zijn de hoge poten gemonteerd.

Houten poten:

Noten mat gelakt

Uitlopend

Eiken houten poten wit geolied of zwart carbon gebeitst.

Poten zijn voorzien van rubber voeten.

ZITKUSSEN

De kern bestaat uit een combinatie van HR-schuim. Boven een HR-schuim met een soortelijk gewicht van 38 kg/m³. Daaronder een zachtere spie die zorgt voor extra comfort en valling in de bank. De schuimkern wordt overtrokken met een hoes gevuld met fiberrilletjes en 'memory' schuimvlokken. (verhouding 30/70%).

RUGKUSSEN

Een gestikte hoes, verdeeld in vakken. Gevuld met een combinatie van dacronrolletjes en 'memory'schuim-vlokken.

ARMKUSSEN (optioneel)

gevuld met veren.

BODY

Wooden construction of beech and mdf.
No-sag springs
Polyether foam covered with 90gr dacron.

FEET

Slede base:

- RVS
- Matt black.

Aluminium legs:

- high-gloss polished
- high-gloss black chrome – plated

The Axel XL is also available with 2 cm lower legs. At the pictured models the high legs are mounted.

Wooden legs:

Solid walnut matt laquered

Expiring

Oak wooden legs, white oiled or black lacquered

Legs are provided with rubber feet.

SEAT CUSHION

Basis of HR foam with thin top with a specific gravity of 38 kg/m³. Underneath a softer wedge with a specific for extra comfort. Latex flocks and fibre curls (ratio 70 / 30%).

BACK CUSHION

An stitched cover, divided in different pockets. Filled with latex flocks and fibre curls.

ARM CUSHION (optional)

Filled with feathers.

KORPUS

Holzkonstruktion von Buchenholz und MDF.
No-sag Federn
Polyäther Schaum bedeckt mit 90gr dacron.

UNTERGESTELL

Kufengestell:

- Edelstahl
- Matt Schwarz

Aluminium Füße:

- Hochglanz poliert
- Hochglanz Schwarz verchromt

Der Axel-XL ist auch erhältlich mit 2 cm niedrigeren Füßen. Beim abgebildeten Modelle sind die hohen Füße montiert.

Holzfüße:

Nussbaum matt lackiert

Ausgehend

Eiche Holzfüße, weiß geölt oder schwarz carbon lackiert

Die Füße sind mit Gummikappen versehen.

SITZKISSEN

Basis aus HR-Schaum mit einem spezifischen Gewicht von 38 kg/m³ unter einer dünnen Oberschicht HR-Schaum für zusätzlichen Komfort. Latex-Flocken und Fiberspiralen (Verhältnis 70 / 30%).

RÜCKENKISSEN

Ein Bezug, unterteilt in verschiedene Oberflächen Füllung von Latex-Flocken und Fiberspiralen.

ARMKISSEN (optional)

Füllung von Federn.

AXEL AXEL XL

Gijs Papavoine

maaiis

DE

KISSEN

Die Rückenkissen des Modells AXEL / AXEL XL haben eine lose Füllung, die aus elastischen, langlebigen Materialien bestehen. Die Kissen schmiegen sich dem Körper an, sind dadurch komfortabel und geben dem Sofa eine "lässige" Ausstrahlung. Damit das Sofa seine Form behält, ist es wichtig, dass es jeden Tag nach Gebrauch abgeklopft wird, damit die Füllung wieder luftig und die Form wiederhergestellt wird (vergleichbar mit einem Kopfkissen).

Diese tägliche Pflege kommt der Lebensdauer und dem Komfort der Kissen zugute und vermeidet ein Verkleben der losen Füllung.

FILZGLEITER UNTER KUFENGESTELL

Die Gleiter unter die Kufengestelle sind aus rutschfestem Material wie Gummi oder Kunststoff gefertigt. Diese Materialien enthalten Substanzen, die unter Druck auf verschiedenen Böden Flecken verursachen können (Kunststoff, Gussböden, PVC, Teppichböden, Betonböden, Holzböden usw.). Um eine Reaktion auf dem Boden zu vermeiden, empfehlen wir die Verwendung von mitgelieferten Filzgleitern.

KUSSENS

De rugkussens van ons model AXEL / AXEL XL hebben een losse vulling. Dit is een vulling van verschillende losse, veerkrachtige en duurzame materialen. De kussens vormen zich gemakkelijk naar uw lichaam en geven daardoor een groot comfort en een natuurlijke nonchalance. Om de vormgeving van uw bank te bewaren is het van belang dat de bank iedere dag na gebruik wordt opgeklopt, zodat de vulling weer luchtig wordt en de vorm wordt hersteld, vergelijkbaar met het hoofdkussen van uw bed. Dit dagelijkse onderhoud komt de levensduur en het comfort van de kussens ten goede en vermijdt verkleving van de losse vulling.

VILTGLIJDERS ONDER SLEDE

De glijdertjes onder de sledes worden gemaakt van antislip materialen, zoals rubber of kunststof. In deze materialen zitten stoffen, die onder druk vlekken kunnen veroorzaken op diverse vloeren (kunststof, gietvloeren, pvc, tapijten, betonnen vloeren, houten vloeren, etc.). Ter voorkoming van een reactie op de vloer, adviseren wij gebruik te maken van bijgeleverde viltglijdertjes.

CUSHIONS

The back cushions of our model AXEL / AXEL XL have a loose fill. This is a filling consisting of various resilient and durable materials. The Axel / Axel XL cushions easily shape to your body and give great comfort and nonchalance. To preserve the design of your couch it is important to fluff it up every day after use to bring back the airy quality of the stuffing and to recover its shape, just as you would do with the pillows on your bed. The life span and comfort of the pillows greatly benefit from this daily maintenance and you prevent the loose stuffing from clumping together.

FELT GLIDES UNDER SLED BASE

The glides under the sled bases are made from anti-slip materials such as rubber or plastic. These materials contain substances which can cause stains under pressure on various floors (artificial floors, cast floors, pvc, carpet, concrete floors, hardwood floors, etc.). To prevent a reaction on the floor we recommend using the included felt glides.

AXEL XL

Gijs Papavoine 2014



AXEL XL

Gijs Papavoine 2014



Slede
RVS

Sled base
stainless steel

Kufengestell
optik Edelstahl

alle onderstellen zijn
hoog en laag verkrijgbaar

All frames are available
in high and low.

Alle Untergestelle sind
hoch und niedrig verfügbar



Aluminium poot
hoogglans
zwart verchromd

Aluminium legs
high-gloss black
chrome-plated

Aluminium Füße hochglanz
Schwarz verchromt



Aluminium poot
hoogglans gepolijst

Aluminium legs
high gloss polished

Aluminium Füße
hochglanz poliert

AXEL XL

Gijs Papavoine 2014

inch = cm x 0.39

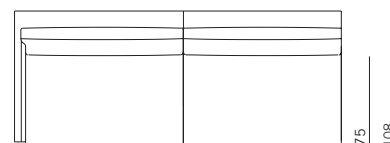
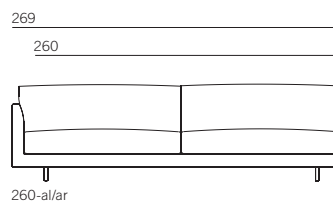
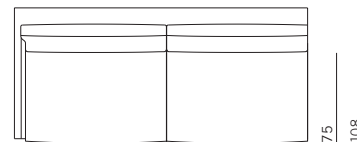
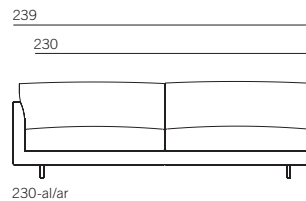
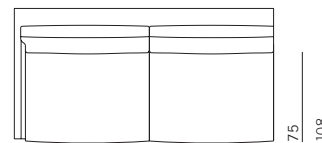
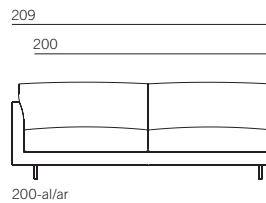
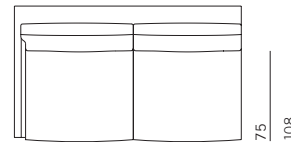
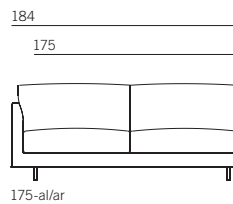
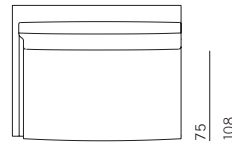
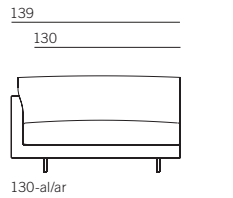
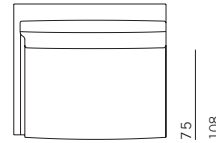
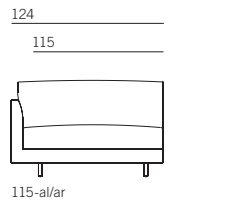
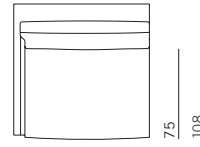
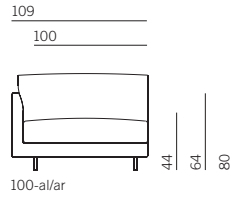
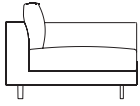

AXEL XL

Gijs Papavoine 2014

inch = cm x 0.39

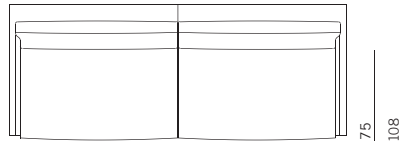
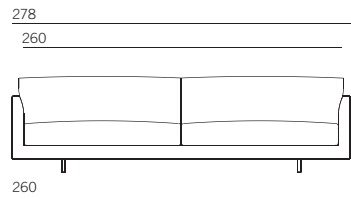
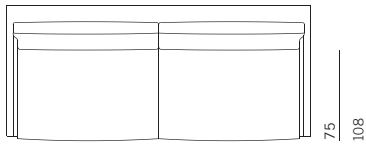
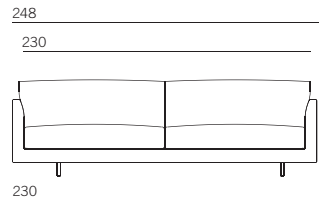
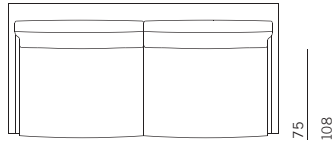
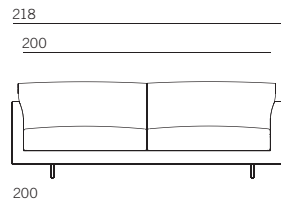
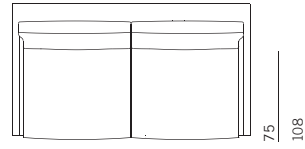
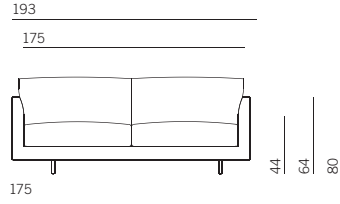
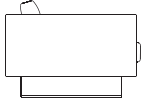

AXEL XL

Gijs Papavoine 2014

inch = cm x 0.39

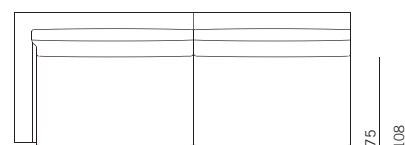
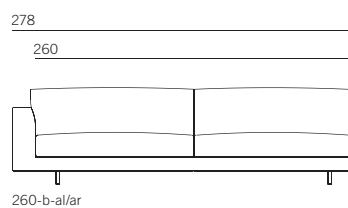
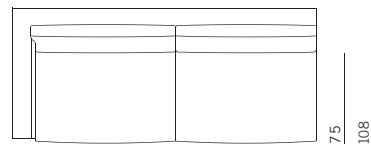
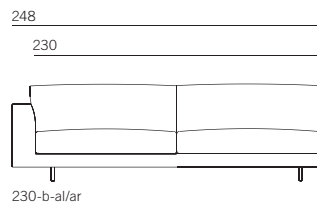
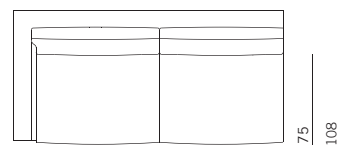
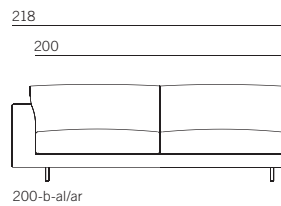
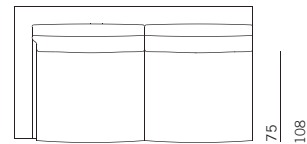
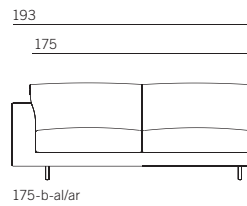
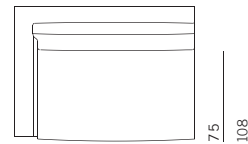
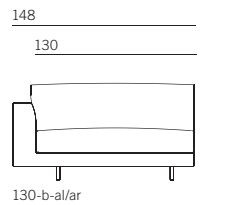
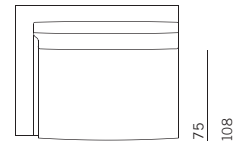
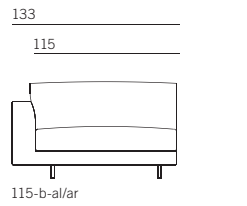
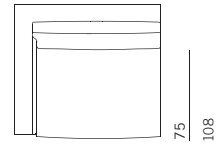
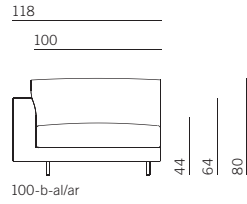
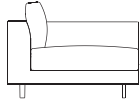

AXEL XL

Gijs Papavoine 2014

inch = cm x 0.39

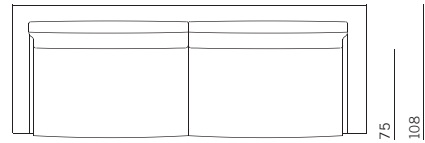
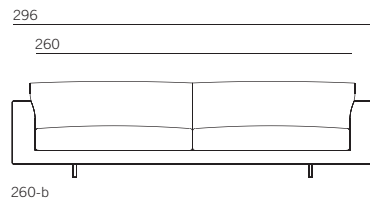
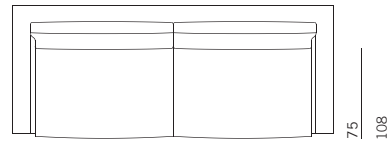
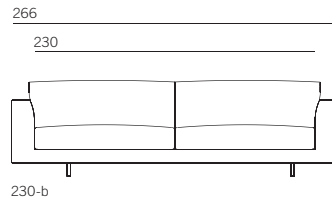
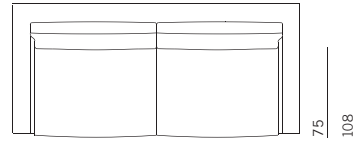
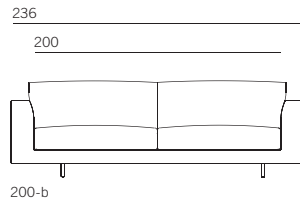
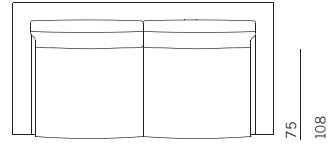
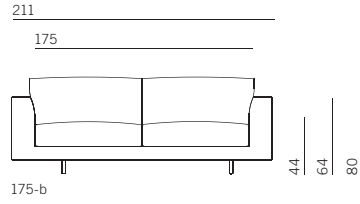
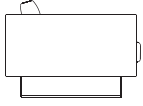

AXEL XL

Gijs Papavoine 2014

inch = cm x 0.39

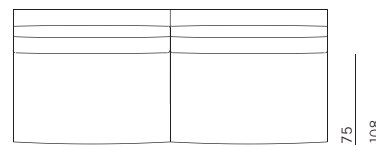
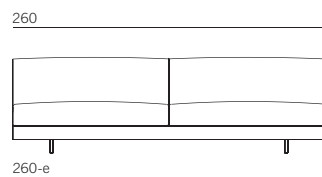
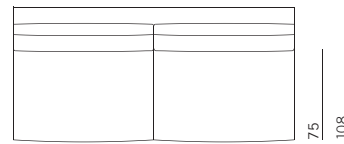
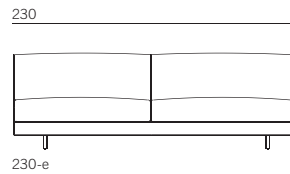
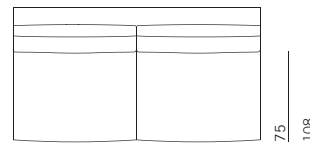
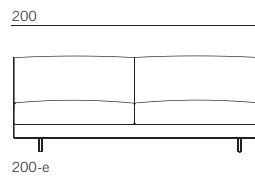
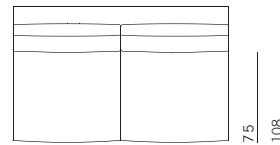
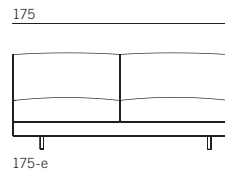
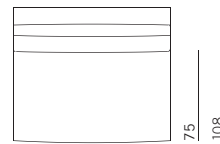
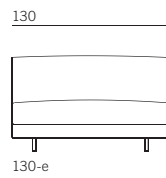
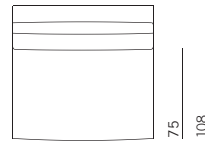
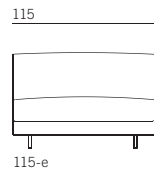
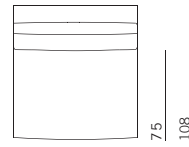
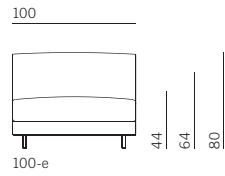
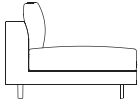

AXEL XL

Gijs Papavoine 2014

inch = cm x 0.39

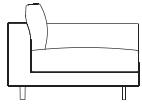

227

176

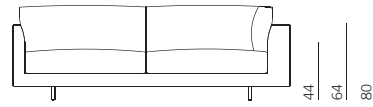

200-H-al/ar

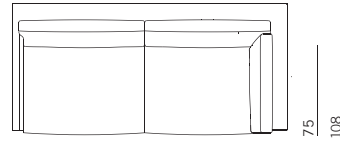

257

206

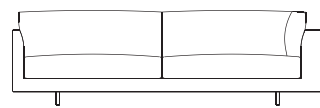

230-H-al/ar

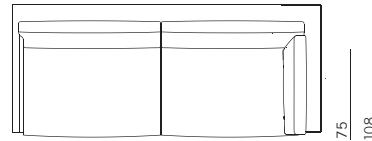

287

236

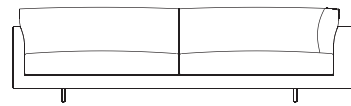

260-H-al/ar

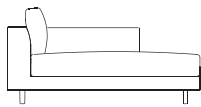
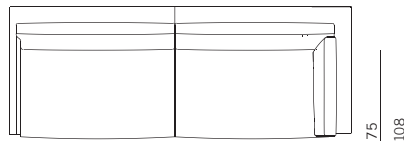

109

100

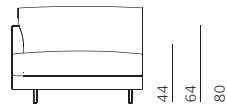

CHL-100-al/ar

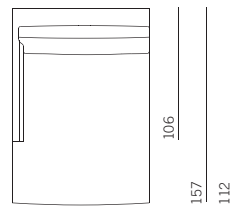

139

130

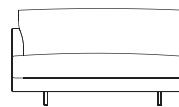

CHL-130-al/ar

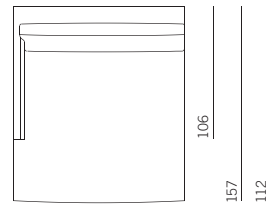

AXEL XL

Gijs Papavoine 2014

inch = cm x 0.39

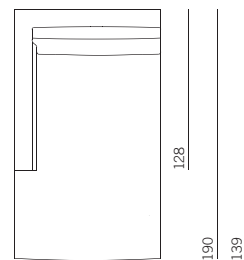
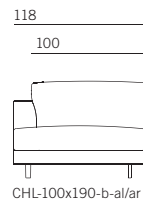
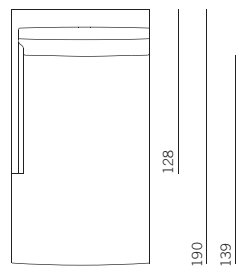
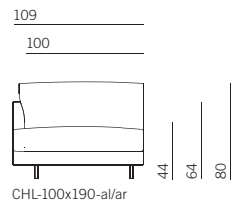
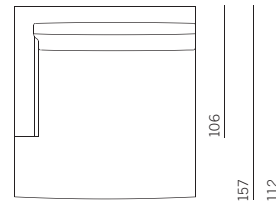
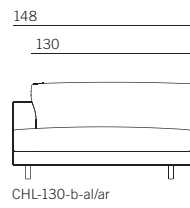
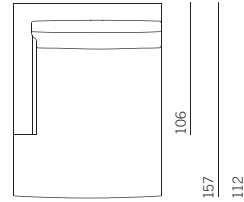
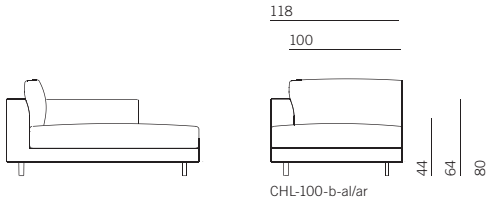

AXEL XL

Gijs Papavoine 2014

inch = cm x 0.39

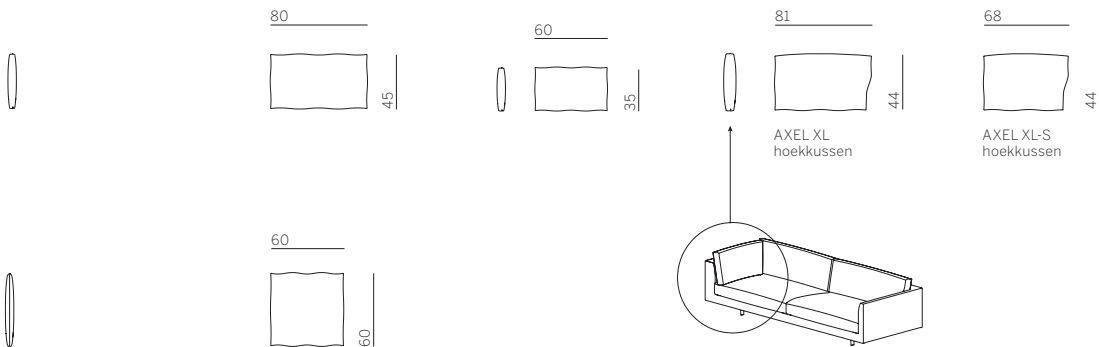
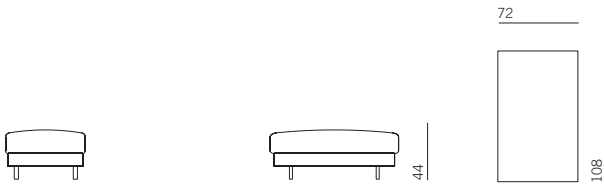
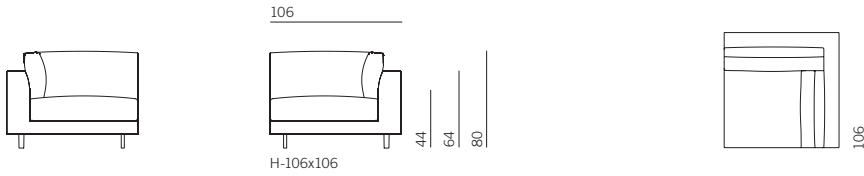

AXEL XL

Gijs Papavoine 2014

inch = cm x 0.39

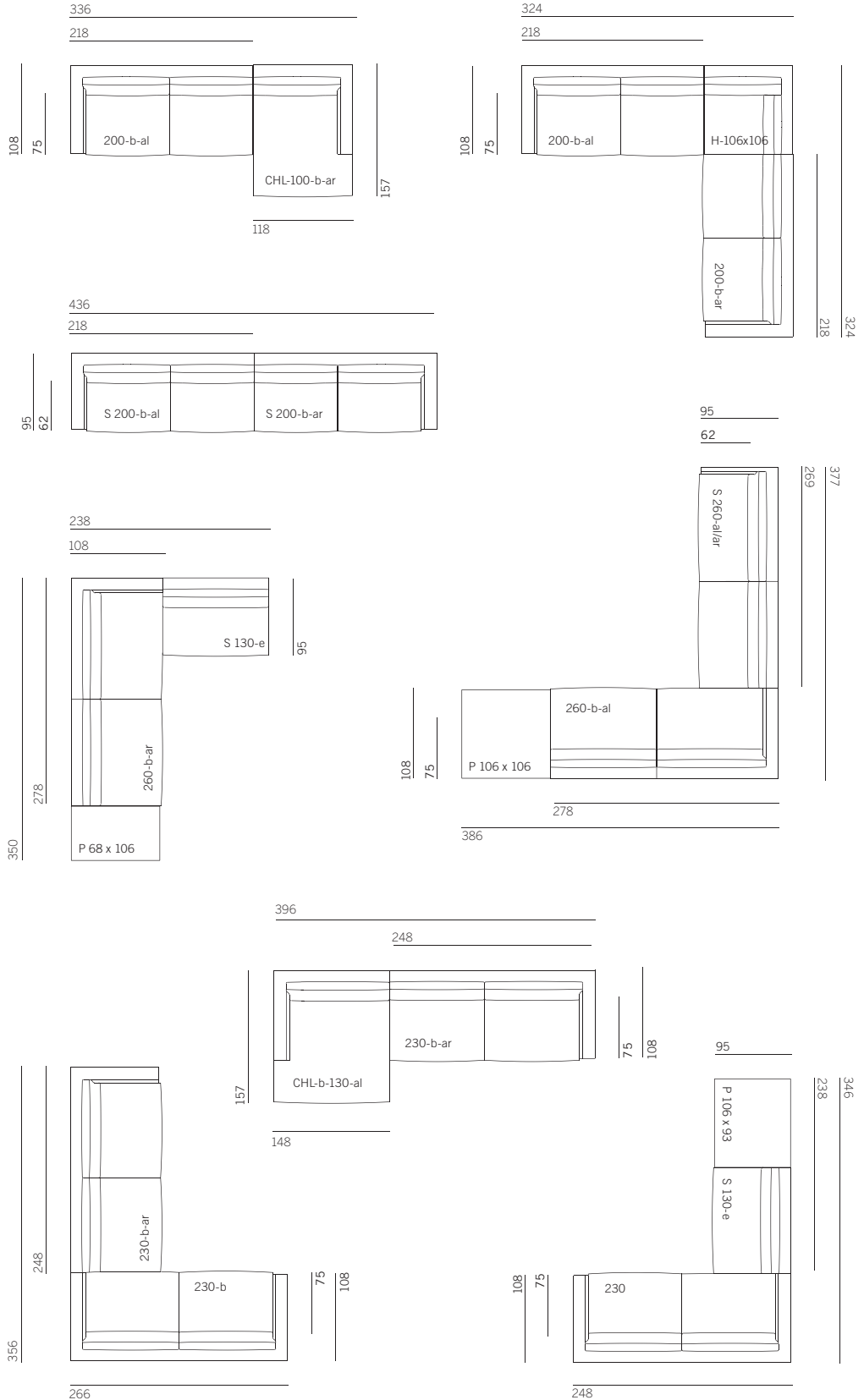

AXEL XL

Gijs Papavoine 2014

inch = cm x 0.39

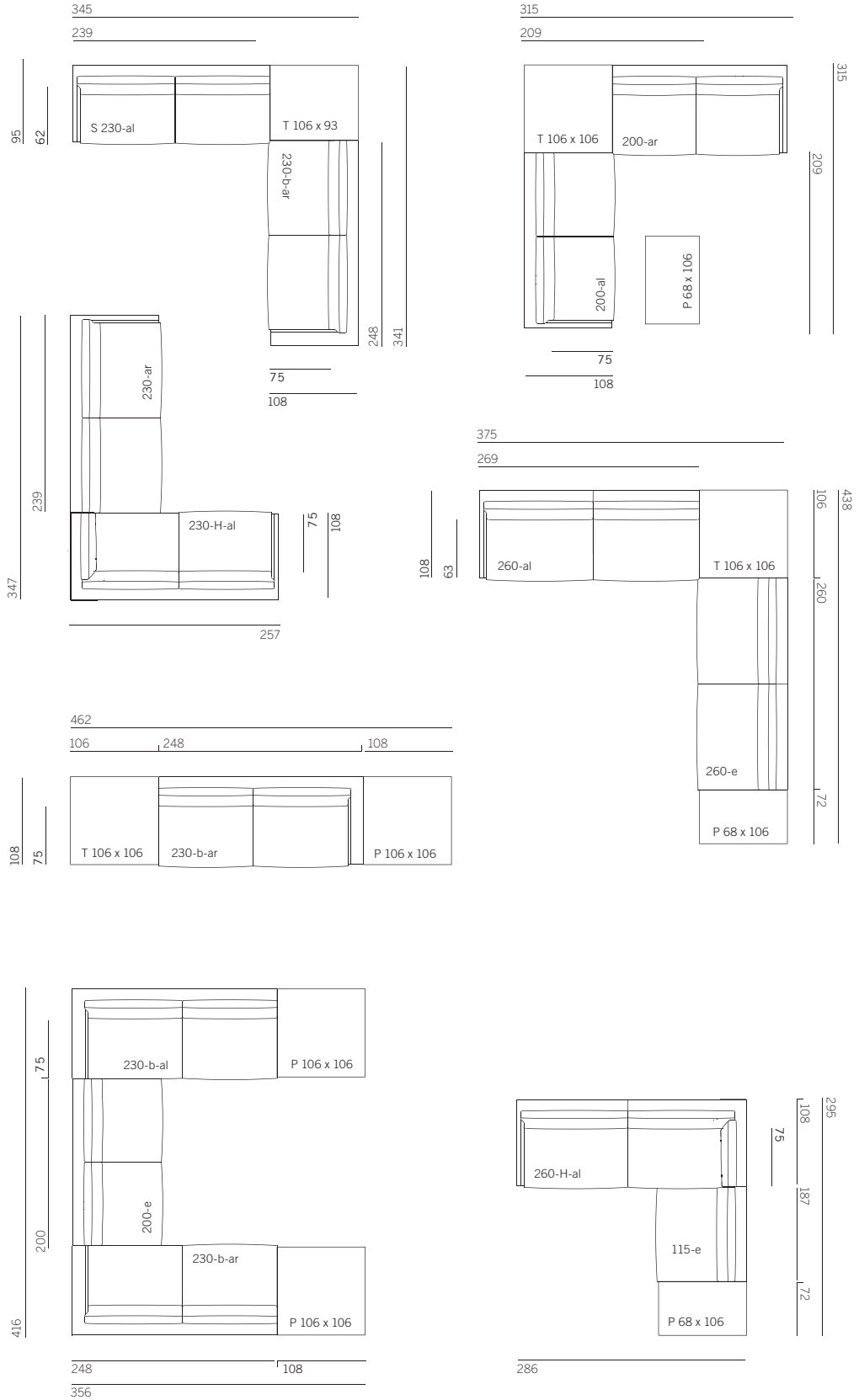

AXEL XL-S

Gijs Papavoine 2014

inch = cm x 0.39

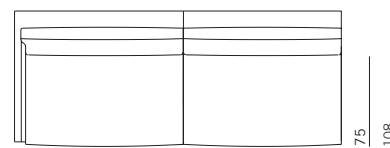
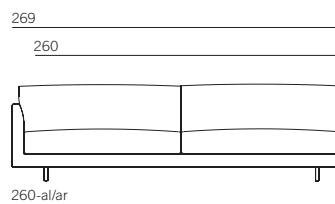
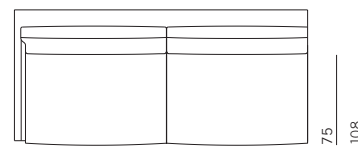
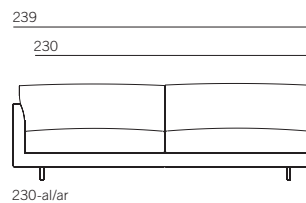
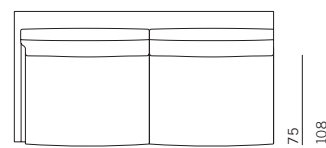
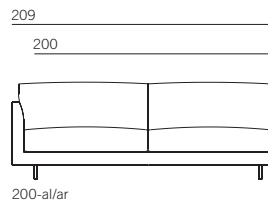
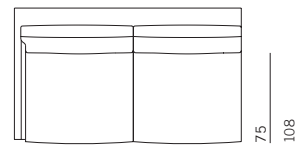
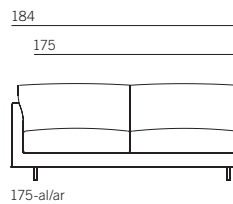
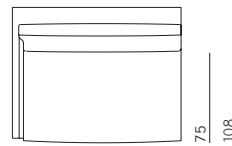
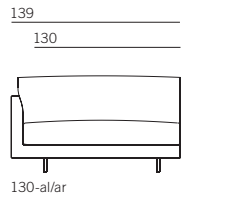
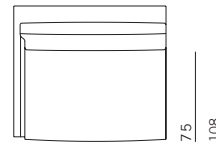
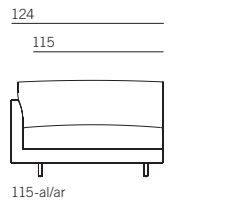
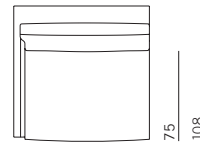
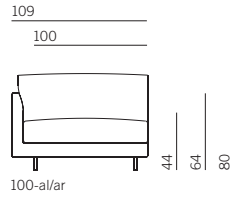
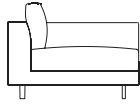

AXEL XL-S

Gijs Papavoine 2014

inch = cm x 0.39

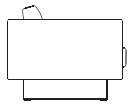

193

175

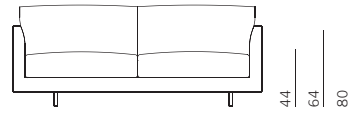

S 175

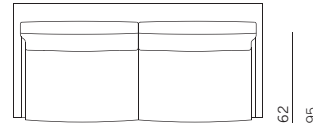

218

200

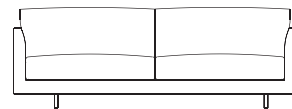

S 200

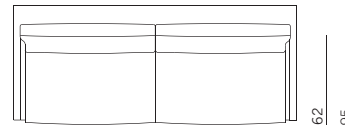

248

230

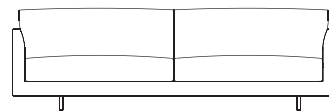

S 230

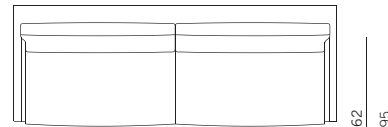

278

260

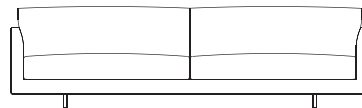

S 260

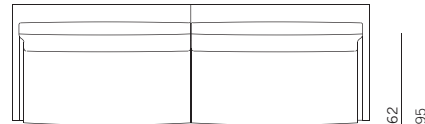

AXEL XL-S

Gijs Papavoine 2014

inch = cm x 0.39

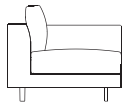

118

100



S 100-b-al/ar

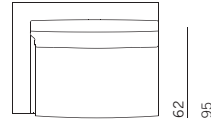

133

115

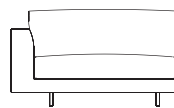

S 115-b-al/ar

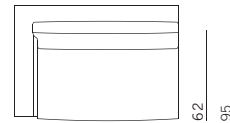

148

130

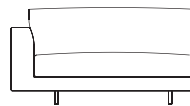

S 130-b-al/ar

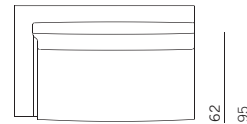

193

175

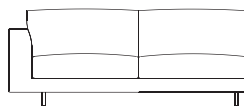

S 175-b-al/ar

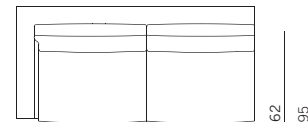

218

200

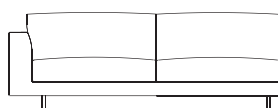

S 200-b-al/ar

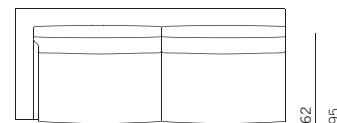

248

230

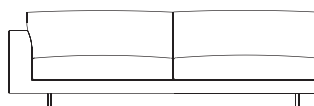

S 230-b-al/ar

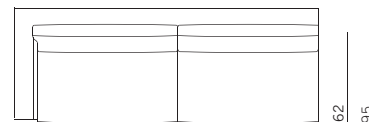

278

260

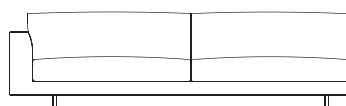

S 260-b-al/ar

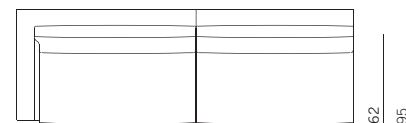

AXEL XL-S

Gijs Papavoine 2014

inch = cm x 0.39

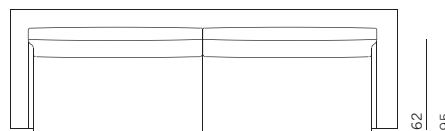
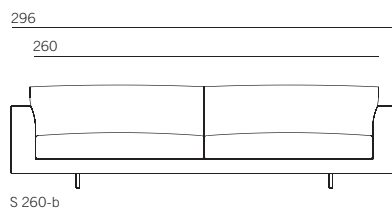
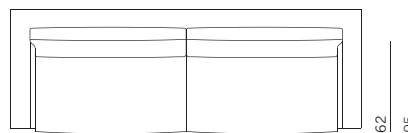
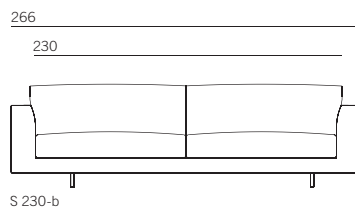
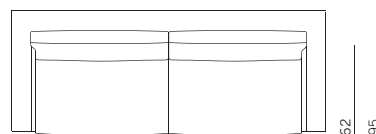
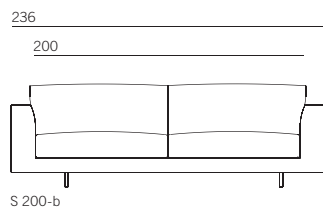
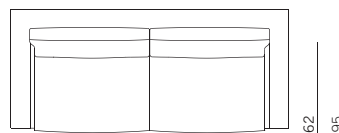
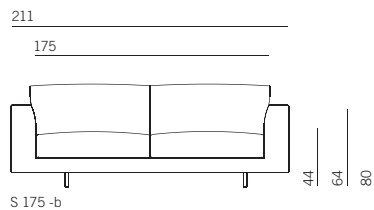
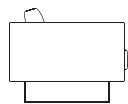

AXEL XL-S

Gijs Papavoine 2014

inch = cm x 0.39

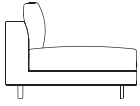

100

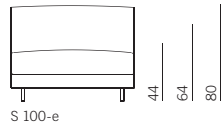

S 100-e

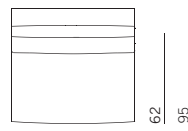

115

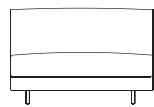

S 115-e

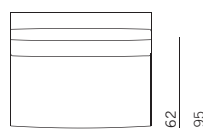

130

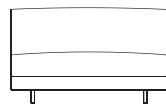

S 130-e

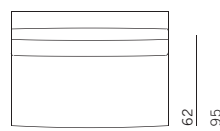

175

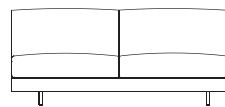

S 175-e

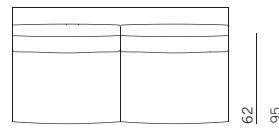

200

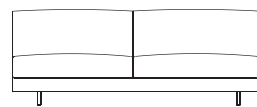

S 200-e

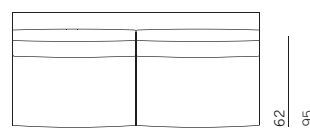

230

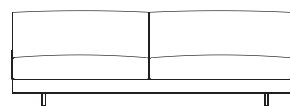

S 230-e

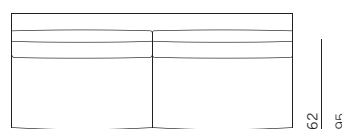

260

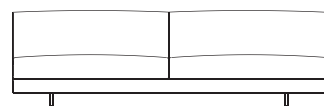

S 260-e

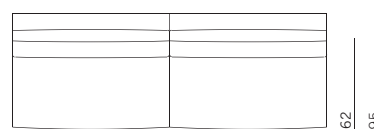

AXEL XL-S

Gijs Papavoine 2014

inch = cm x 0.39

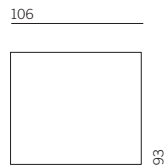
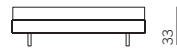
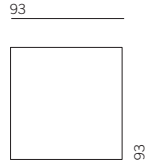
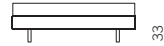
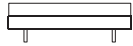
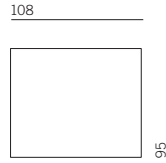
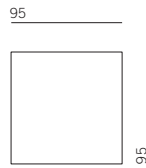
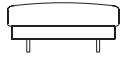
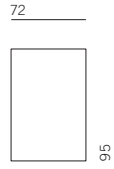
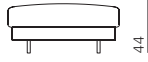

AXEL XL-S

Gijs Papavoine 2015

HOOFDSTEUN

De zijkanten van de hoofdsteun zijn te verstellen.

De hoofdsteun is naar voren te verstellen.

Axel XL-S hoofdsteun, vooral aanbevolen bij de XL-S variant.

HEADREST

The sides of the headrest can be adjusted.

The headrest can be adjusted forwards.

The Axel XL-S head rest is especially recommended for the XL-S version.

NACKENSTÜTZE

Die Seiten der Nackenstütze können eingestellt werden.

Die Nackenstütze kann nach vorne eingestellt werden.

Axel XL-S Nackenstütze, besonders empfohlen für XL-S Variante.

